

of excavator guidance

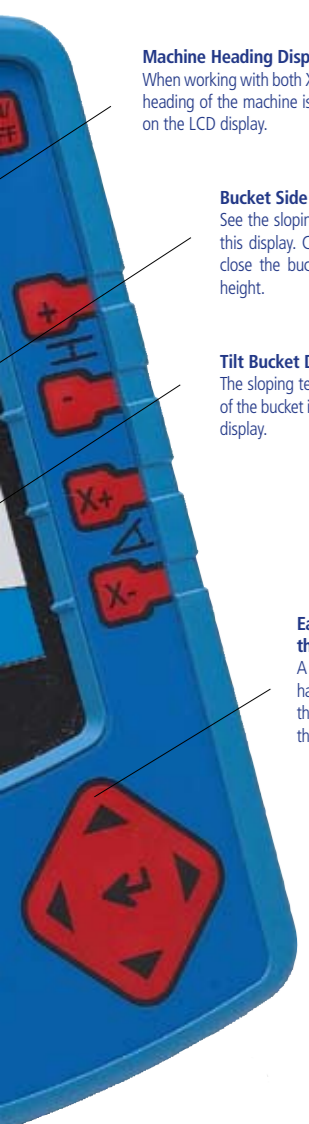

Machine Heading Display

When working with both X and Y slopes the heading of the machine is clearly displayed on the LCD display.

Bucket Side View Display

See the sloping terrain and your bucket on this display. Check if you need to open or close the bucket or to correct the bucket height.

Tilt Bucket Display

The sloping terrain as well as the actual tilt of the bucket is clearly displayed on the LCD display.

Easy navigation through menus

A QuickNav™ multifunction button has been added. This button will aid the driver to quickly navigate through the XC 2 menus.

What can I do with a MikroDigger™ system?

With a MikroDigger™ the XC2 control box will clearly guide you to:

- A preset reference depth or slope
- A reference surface sloping in both directions (RS10 required)
- A complex profile of up to 11 combined surfaces
- You can offset your reference surface
- Use a point or a string line as height reference
- Use a laser (plane or slope) as reference
- You can measure distances and slopes
- Do blind cuts under water etc.

All this information will be displayed to you on the crisp and clear LCD display of the XC2 control box.

Will it benefit me?

The MikroDigger™ guidance system is essentially made to improve the overall performance of you and your machine. You will become more productive because you will:

- Get done in fewer passes
- Be able to excavate more accurately
- No more over excavations
- Be your own surveyor and save money
- Limits the cost for ground personnel.

A MikroDigger™ guidance system will ensure your future position in the ever more competitive construction market



TECHNICAL DATA

XC2 Control Box	
Graphic Display:	4" LCD
Size (WxHxD):	12x16x5 cm (4,7x6,3x2,0 in)
Supply:	9-28V full polarity and load dump protected
Operating temperature:	-40 to 70C (-40 to 160F)
Seal:	Dust and waterproof (IP66)

XIS1 inclination Sensor	
Housing:	All steel
CAN Connection:	Two M12 connector
Size:	8x12x3 com (3,1x4,7x1,2 in)
Operating angle:	180 deg
Operating temperature:	-40 to 70C (-40 to 160F)
Seal:	Hermetically sealed (IP68)

XIS1L inclination Sensor	
Housing:	All steel
Laser window:	5 cm (2,0 in) integrated laser receiver
CAN Connection:	Two M12 connector
Size:	8x12x3 (3,1x4,7x1,2 in)
Operating angle:	180 deg
Operating temperature:	-40 to 70C (-40 to 160F)
Seal:	Hermetically sealed (IP68)

XIS2 inclination Sensor	
Housing:	All steel
CAN Connection:	One M12 connector
Size:	2,5x2,5x5,0 cm (1,0x1,0x2,0 in)
Operating angle:	360 deg
Operating temperature:	-40 to 70C (-40 to 160F)
Seal:	Hermetically sealed (IP68)

RS10 Pitch, Roll and Direction Sensor	
Housing:	All steel
CAN Connection:	Two M12 connector
Size:	Diameter 7 cm. (2,8 in) Height 80 cm (31,5 in) including mast
Direction sensor:	360 deg ± 3 deg
Pitch and roll angle:	180 deg
Operating temperature:	-40 to 70C (-40 to 160F)
Seal:	Dust and waterproof (IP67)

Will it fit my machine?

A MikroDigger™ guidance system can be fitted on any machine ranging from 1 to 600 plus tons, dual booms or long reach machines with a reach of more than 25m (80') – the standard system will fit them all. And the installation is easy. A standard system is typically installed and calibrated in less than 3 hours.

Is this OK?

- Most accurate system on the market – 1 cm (0,5") or 0.2% of the reach.
- More than 30 functions
- Fits any machine
- 4" Colour Graphic display and very easy to use.
- Holds 20 different bucket settings.
- 100% waterproof (IP68) – no special sensors or cables needed for underwater use.
- Upgradeable from single grade to dual grade.
- Upgrade with tilt bucket sensor.
- Upgradeable from dual grade to 3D guidance.
- Bucket sensor can be mounted on the dog bone.
- Often used function keys can be activated from the joystick.



Mikrofy A/S · Bondovej 16 · 5250 Odense SV · Denmark · www.mikrofy.com

Since the start in 1987 Mikrofy A/S has placed itself among the top-five worldwide manufacturers of professional precision lasers and machine control systems. The profits of the business are reinvested in new products and growing the business. Mikrofy is built upon sound principals of developing and manufacturing state-of-the-art products, supported by experts and cooperating with outstanding professional local distributors.



AUTHORIZED MIKROFYN DISTRIBUTOR:

MikroDigger™ XC 2

Setting new standards for excavator guidance worldwide



The next generation of excavator guidance is right here!



Several thousand MikroDigger™ machine control systems are working all over the world.

MikroDigger™ means better performance

The constant development of sensors and software has made it the most accurate and reliable system on the market, improving your daily work, and securing excellent productivity for users.

MikroDigger™ means better features

If you think that an excavator guidance system is a new feature – then think again. Our latest XC2 control box is just the next generation in the line of the well proven MikroDigger™ excavator guidance system that was launched back in 1996.

MikroDigger™ means flexibility

The MikroDigger™ is a truly upgradeable system. You can start with a single grade system that will allow you to do most operations such as fixed depth, slopes, trench-ing, blind cuts, grading etc.

MikroDigger™ upgrade

Adding on the RS10 Sensor will upgrade your system to dual grade system. It will give you the freedom of movement in any direction on a sloping surface as the control box will calculate and display the correct bucket tilt angle. Mounting a tilt bucket sensor will add a further dimension to your machine control.

Upgrade to 3D guidance

A growing number of our customers have also chosen to upgrade their MikroDigger to a 3D capable system. This can be done by adding the external GeoRog computer or by upgrading to the VisualDigger 3D software and the “all in one” XC3D compact control box that acts as both control box for the excavator system, 3D computer executing the VisualDigger 3D software and as control panel for the RTK GPS receiver (Leica MNS1200 and GSM5).

Multiple and improved bucket position indicators

A multicolour bucket display visualizes the bucket position. Essential when digging under water, in deep trenches or elsewhere where the bucket is out of sight. A new bucket display for cross slope bucket control has also been added for better functionality.

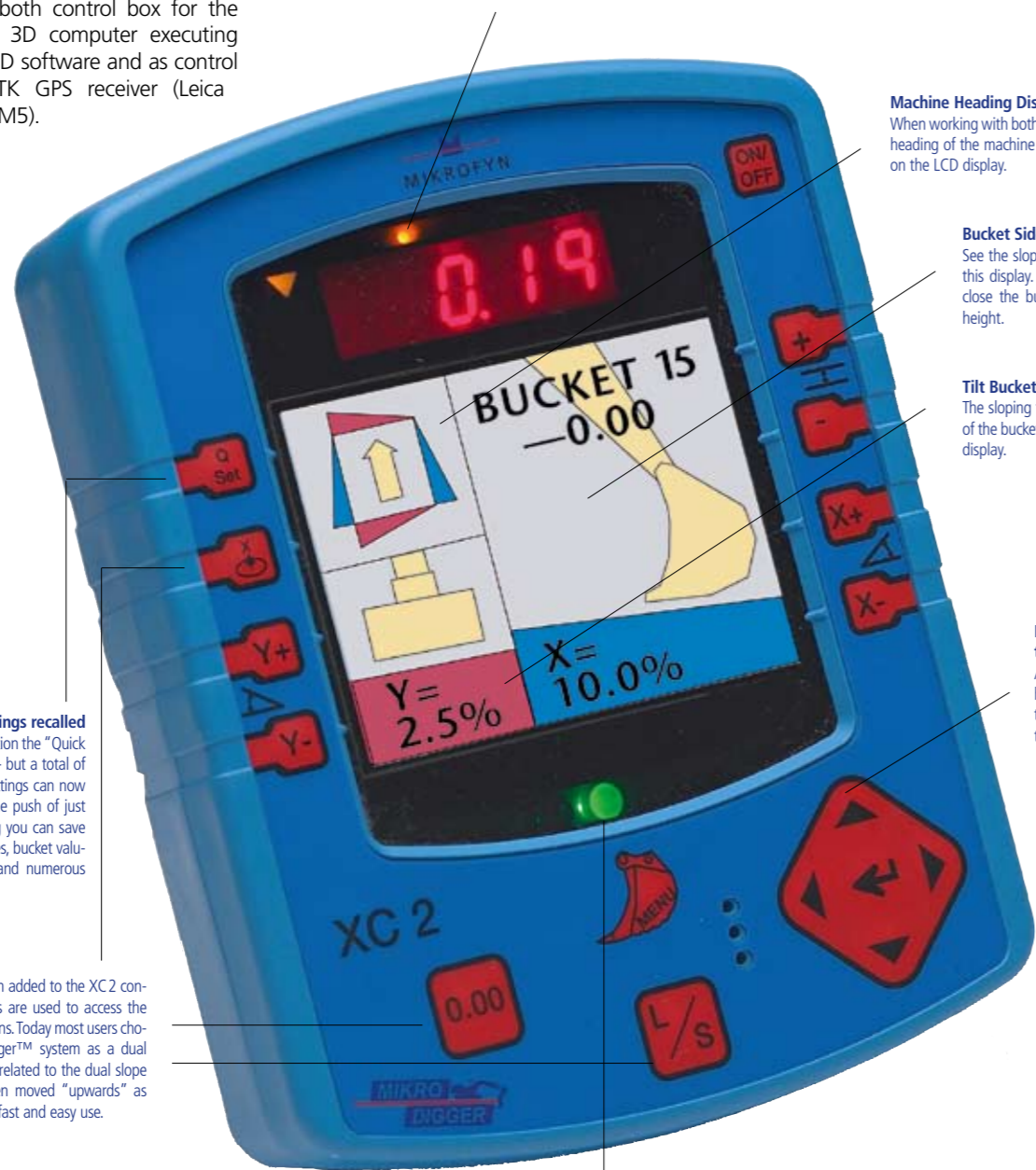

Machine Heading Display

When working with both X and Y slopes the heading of the machine is clearly displayed on the LCD display.

Bucket Side View Display

See the sloping terrain and your bucket on this display. Check if you need to open or close the bucket or to correct the bucket height.

Tilt Bucket Display

The sloping terrain as well as the actual tilt of the bucket is clearly displayed on the LCD display.

Easy navigation through menus

A QuickNav™ multifunction button has been added. This button will aid the driver to quickly navigate through the XC 2 menus.

Multiple and improved bucket displays

A multicolour bucket display visualizes the bucket position. Essential when digging under water, in deep trenches or elsewhere where the bucket is out of sight. A new bucket display for cross slope bucket control has also been added for better functionality.

4" Full Colour LCD Graphic Display

At just a glance - you can overlook all guidance and status information on the crisp and clear LCD display - even in direct sunlight. This - combi-ned with the bright LED numbers and possibility for guidance by audio signals - makes the MikroDigger™ system the most versatile system on the market.

The sensor system:

The sensors for the MikroDigger™ excavator system are gravitational reference sensors. The sensor technology and software have been under constant development since the introduction back in 1996. This development has led to the sensors being the most responsive and accurate excavator sensor on the market.

Durable sensors

All sensors are fully waterproof down to at least 20m (70') head of water – and so are the cables - so there is no need for expensive special equipment for backhoe dredgers. The hermetically sealed sensors will also withstand the stress and vibration on a hydraulic hammer.

CAN bus equals quick installation

Mikrofyn was the first in the industry to use the CAN bus cable connection system. The CAN bus system enables to connect as many sensors as needed with just one cable. This makes installation extremely simple. We know that minimizing downtime is important for your business. Therefore all Mikrofyn sensors come with special welding plates or easy mounts to speed up the installation. The typical installation and calibration time for a basic system is less than three hours. To be this effective we ask that all Mikrofyn fitters go through a thorough education at the factory before they are let out on their own.



Basic System

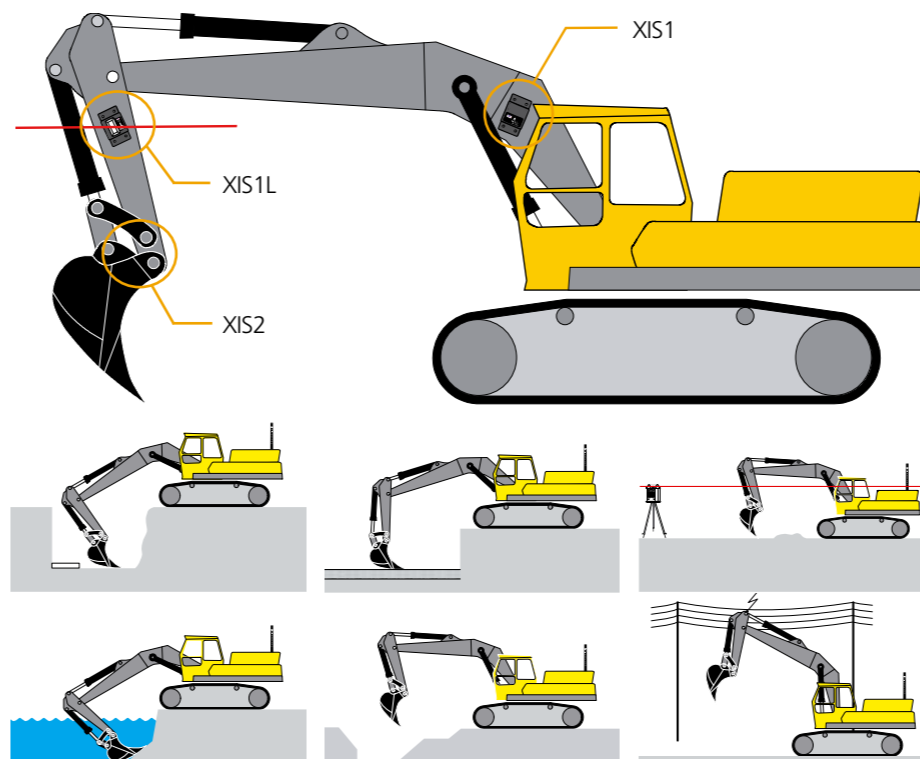

You have a choice between a variety of sensors for your excavator.



XIS1 Excavator sensor
Can be used as boom, stick or bucket sensor. Normally it is only used as the boom sensor. If you have a dual boom machine we just mount two XIS1 sensors.



XIS1LA Stick sensor
Why mount two sensors when you can combine everything in one? The XIS1LA is a combined stick angle and laser sensor. It's compact and easy to position in the right spot.

XIS2B Bucket sensor

This 360° bucket sensor can be mounted on the bucket, in the quick coupler or on the dog bone. The small size allows for it to be “hidden” in a protected location to avoid damage to cable or sensor.



XIS1 Tilt bucket sensor
You can also update your MikroDigger to include a sensor for a tilt bucket. The compact size makes it easy to hide in the quick coupler.



RS10 Pitch, roll and direction sensor
The RS10 is a pitch, roll and direction sensor used to determine the altitude of the excavator. While working, the accurate roll and pitch measurement from the RS10 easily compensate for the rolling and pitching motion of the machine to give the required cm-accuracy (sub-inch level).

Dual Slope System

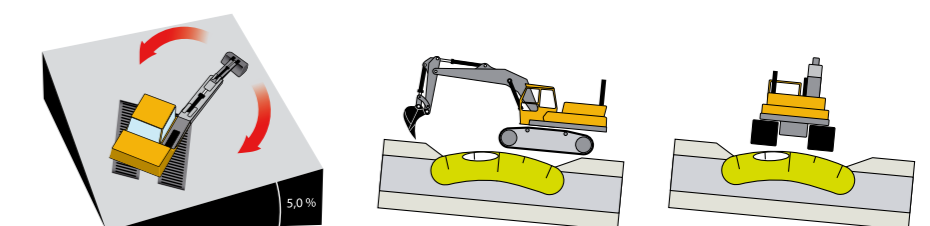
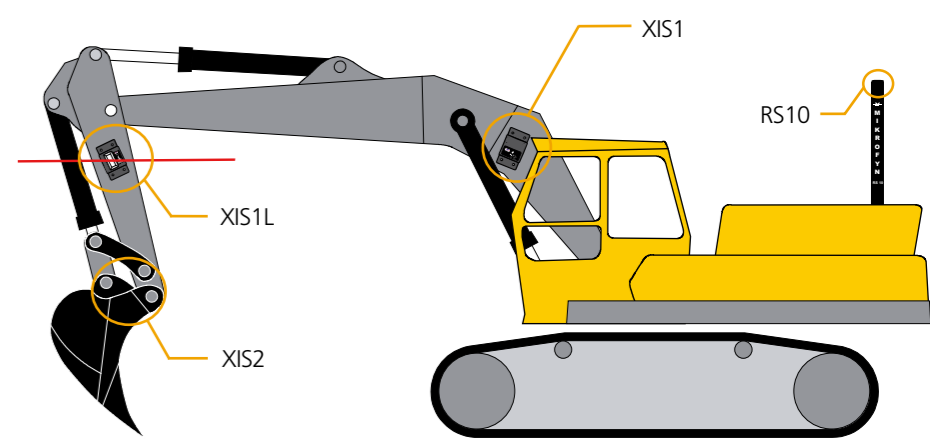

Tilt Bucket Control

